

6 5 4 3 2 1

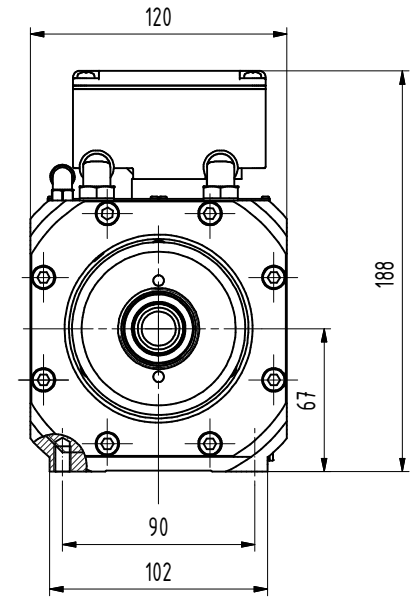
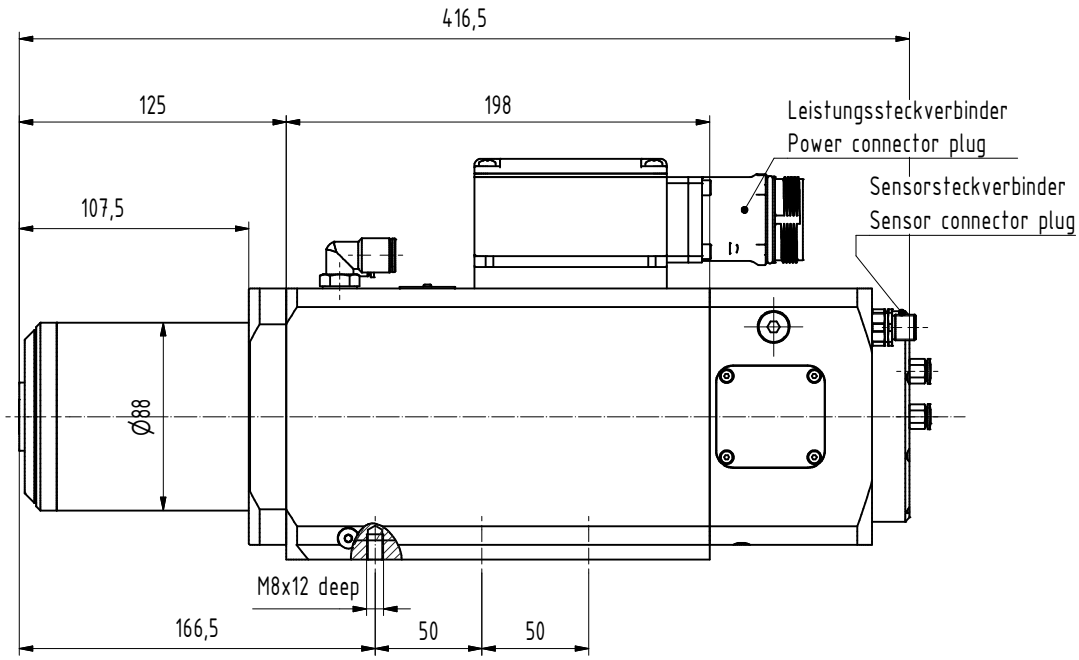
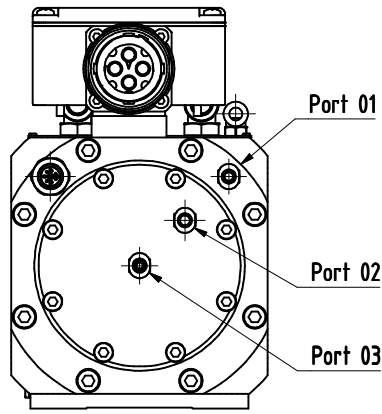

Luftzufuhr Löseeinheit / Tool change air supply:

- Port 01 G 1/8" Werkzeug spannen / tool clamping
- Port 02 G 1/8" Werkzeug lösen / tool release
- Port 03 G 1/8" Kegelreinigung / taper cleaning air

- Port 04 G 1/8" Sperrluft / Purge air
- Port 11 G 1/4" Kühlung Eintritt / Coolant IN

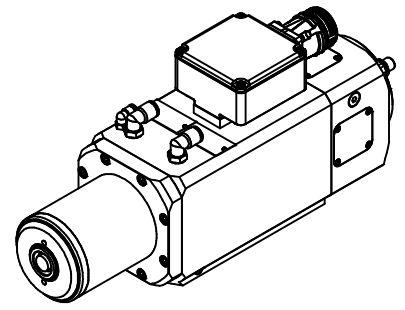
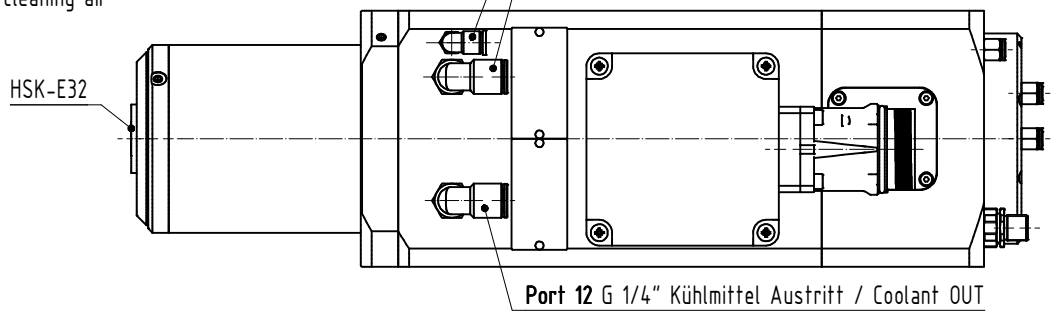

Sf-00-06-058/6

Diese Zeichnung ist Eigentum der Walter Perske GmbH, Friedrich-Ebert-Straße 80-84, 68167 Mannheim. Schutzrecht nach DIN 34 beachtet!		Allgemeintoleranzen n. DIN ISO 2768-1	Maßstab	Gewicht: <b>21,4 kg</b>
		Datum	Name	Werkstoff:
		13.09.2018	r.sternagel	<b>Motorspindel / ATC</b> VQWS 60 DD - HSK-E32
		Kontrolliert		
		Norm		
		<b>perske</b>		Blatt 1/2
Status	Änderung	Datum	Name	A3
			Ersatz für:	<b>MS 165-5</b>
			Ersetzt durch:	MS 165-5 KK-DH IVGS 60 DD) IMS 165-51idw

6 5 4 3 2 1