

Typ	a	e	k	z
KRS 35.1	145	165	238	212
KRS 35.3	175	195	268	242
KRS 35.5	215	235	308	282
KRS 35.7	235	255	328	302
KRS 35.9	275	295	368	342

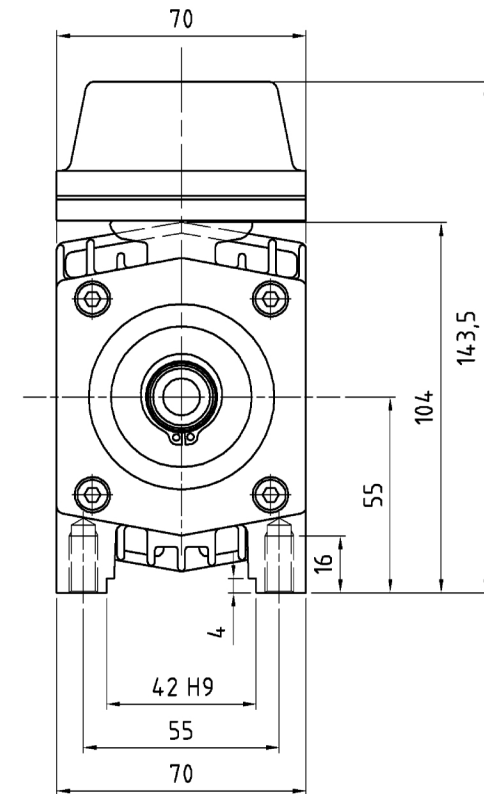

Rego-Fix Spannzanze ER16  
und Spannmutter ER16M  
Spannbereich 0,5...10

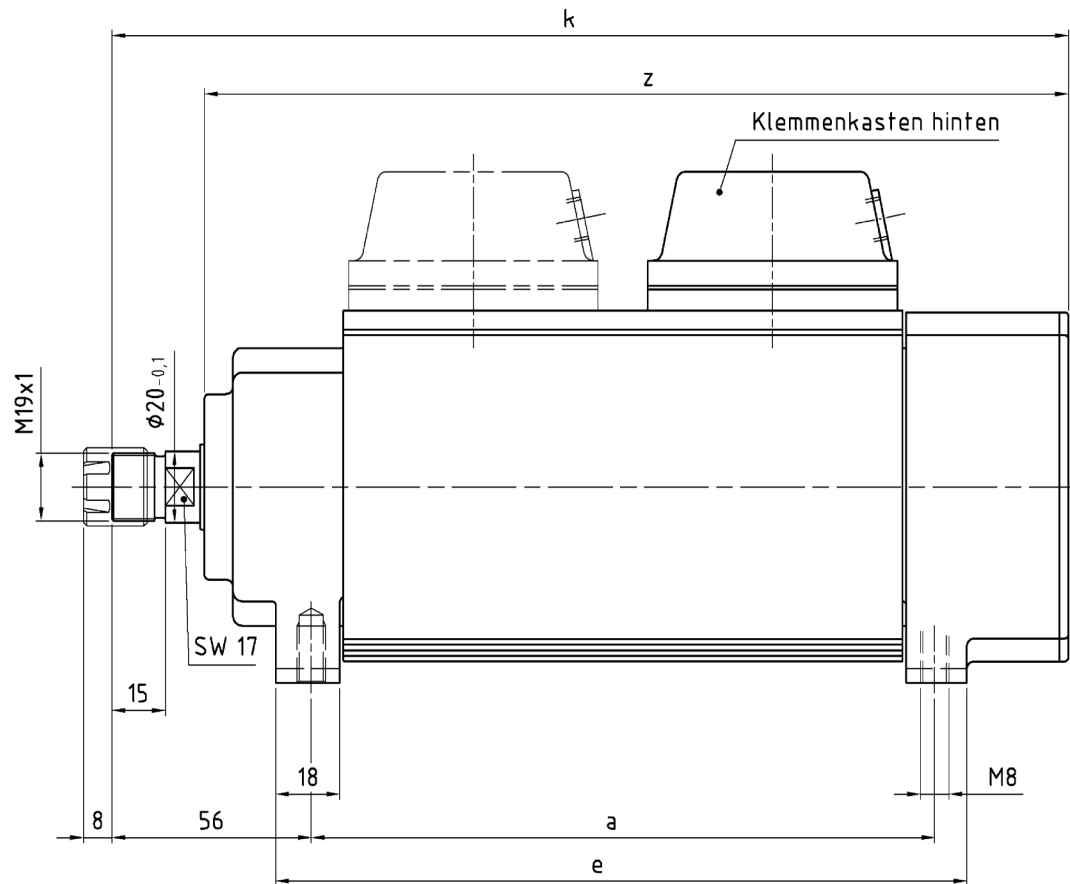
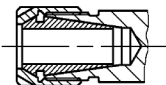

A	Gehäuse und Zwischenplatte geändert	24.11.05	Fogl
Zust.	Änderungen	Datum	Name

Datum	Name
Bearb. 19.01.98	Frie
Gepr.	
Maßstab 1:15	

Flachmotor  
KRS 35



Stückliste  
00 03 007/11

**MS 3871**

Blatt  
1/1